



## OF 700 oil dehydrator

**High capacity solids-ejecting centrifuge for oil dehydration in the oil & gas industry**

The Alfa Laval centrifuges for the oil and gas industry are available in many different sizes and configurations, each one designed and adapted to the widely varying separation tasks encountered. A new range of separators for this industry is developed with the focus on high separation performance, low power consumption and high corrosion resistance.

The OF 700 dehydrator is designed for treating water containing oils in the oil and gas industry, both onshore and offshore.

With a feed flow capacity of up to 70 m<sup>3</sup>/h (310 US gpm)\* and high solids handling capability the OF 700 dehydrator is ideal for the tough conditions common in the chemical industry. It is a unit separating two non-miscible liquid phases, at the same time providing automatic intermittent discharge of solids with high dry matter content. Thanks to the internal disk-stack and the centrifugal force the most challenging oil feeds can be treated, such as those with small density differences or small water droplets

The OF 700 dehydrator is semi-hermetic and features feed through the bottom end of the hollow bowl spindle. The semi-hermetic inlet ensures maximal separation performance and low power consumption.

The OF 700 dehydrator Ex1 and OF 700 dehydrator Ex2 are ATEX approved for use in Zones 1 and 2, respectively. The OF 700 dehydrator Ex1 version is designed for inert gas blanketing. A non-ATEX version is also available.

\* Actual recommended capacity depends on each specific case

### Applications

The OF 700 dehydrator is used for treating water-containing oil streams, separating two non-miscible liquid phases, at the same time removing suspended solids with particle sizes from approximately 0.5 to 500 µm from liquids having lower densities than the solids. The recommended capacity is defined case by case. Alfa Laval has long experience in the application and will ensure optimal separation performance.



OF 700 oil dehydrator complete with motor

Because the OF 700 dehydrator is designed to be flexible, it performs equally well in the different conditions met with in most processes.

### Standard design

All metallic parts that come in contact with the process liquid are made of high-grade stainless steel with high level of corrosion resistance. Liquid-wetted rubber gaskets and O-rings are made of Viton or Teflon-encapsulated Viton. The connections are ANSI flanges. The bowl casing is prepared for cooling and sound-dampening when required. Fitted flushing nozzles allow for cleaning above and below the bowl.

### Special features

The OF 700 dehydrator is based on a unique, semi-hermetic design concept specifically optimized for treating water-containing oil. The hermetic, bottom-feed inlet ensures a gentle acceleration of the process liquid. This minimizes splitting of shear-sensitive droplets and particles, maximizing separation performance. Another benefit of the semi-hermetic inlet is a power saving of up to 20%, which is beneficial both for OPEX and environmental aspects.

The discharge volume is adjustable. It ensures discharge of solids with high dry matter content.

The separator is equipped with built-in paring discs for the separated liquids, eliminating the need for external pumps. A paring disc is a stationary device with the shape of a pump wheel.

The sliding bowl bottom is fitted with an easily exchangeable erosion liner for protection against possible abrasive solids. Replaceable port liners protect the discharge ports of the bowl body.

The presence of a frequency inverter in the drive system gives a number of advantages, including low starting current, and a short-time power supply at external power failure.

### Operating principles

The feed is introduced into the rotating centrifuge bowl from the bottom via the hollow bowl spindle (1) and accelerated in a distributor (2) before entering the disc stack (3). The separation takes place between the discs. The light liquid phase moves towards the centre of the bowl where it is pumped out under pressure by means of a built-in paring disc (4). The heavy liquid phase moves towards the periphery, flows over a top disc and is pumped out by means of a paring disc (5). The heavy solids phase is collected at the periphery of the bowl where it is discharged intermittently via the centrifuge cyclone.

The solids discharge is controlled by a hydraulic system below the separation space in the bowl, which at certain intervals forces the sliding bowl bottom (6) to drop down thus opening the solids ports (7) at the periphery of the bowl. The triggering system functions by outlet turbidity and/or timer.

### Basic executions

OF 700 dehydrator Ex1 for ATEX zone 1  
OF 700 dehydrator Ex2 for ATEX zone 2

### Basic equipment

Each OF 700 dehydrator comes complete with flameproof electric motor with frequency inverter, speed sensor, vibration sensor, vibration-dampening feet, set of tools and standard set of spares.

### Options

The frame can be delivered in two executions: painted or clad with stainless steel.

### Optional extras

The OF 700 dehydrator can be delivered as a complete fully automated system on skid, including valve modules for process and service liquids, starter and control system, and CIP system. For installation in hazardous area Zone 1 the unit is supplied with an inert gas system.

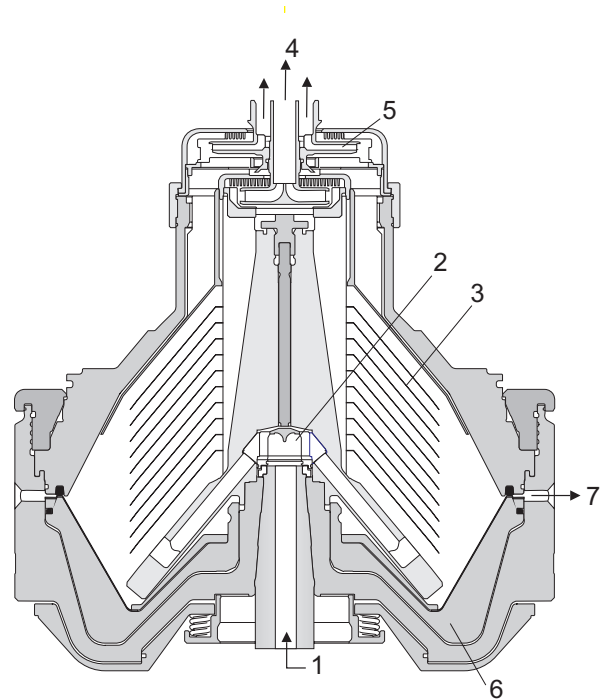

Typical semi-hermetic bowl for a solids-ejecting three-phase centrifuge. The details illustrated do not necessarily correspond to the centrifuge described.

### Material data

Bowl body, hood and lock ring	s.s. 1.4501 UNS S 32760
Bowl discs	Stainless steel 1.4547 UNS S 31254
Frame top part and hood	s.s. 1.4401 UNS 31600
Frame bottom part	Cast iron, with or without cladding in stainless steel 1.4301 UNS 30400
Inlet and outlet parts	Stainless steel 1.4401 UNS 31600
Gaskets and O-rings	Viton

### Shipping data (approximate)

Centrifuge incl. bowl and motor	2550 kg (5,600 lbs)
Bowl	1150 kg (2,600 lbs)
Gross weight	2800 kg (6,200 lbs)
Volume	8 m <sup>3</sup> (280 cuft)

### Technical specifications

Hydraulic capacity	70 m <sup>3</sup> /h (310 US gpm)
Bowl speed	4,800 rpm
Adjustable discharge volume	10 to 26 l (2.6 to 6.9 US gal)
Solids handling capacity	1,540 l/h (6.8 US gpm) <sup>1)</sup>
Motor power installed	max. 67 kW (90 HP)
Feed temperature range	0–100°C (32–212°F)
Inlet pressure at 70 m <sup>3</sup> /h at inlet flange	300 kPa (14 psig)
Sound pressure	80 dB(A) <sup>2)</sup>
Overhead hoist lifting capacity	min. 1,160 kg (2,600 lbs)

<sup>1)</sup> Wet solids

<sup>2)</sup> In compliance with EN ISO 3744

### ATEX design codes

EX II 2 G c II B T4 X for zone 1	With inert gas purging
EX II 3 G c II B T4 X for zone 2	Electrically protected

### Dimensions

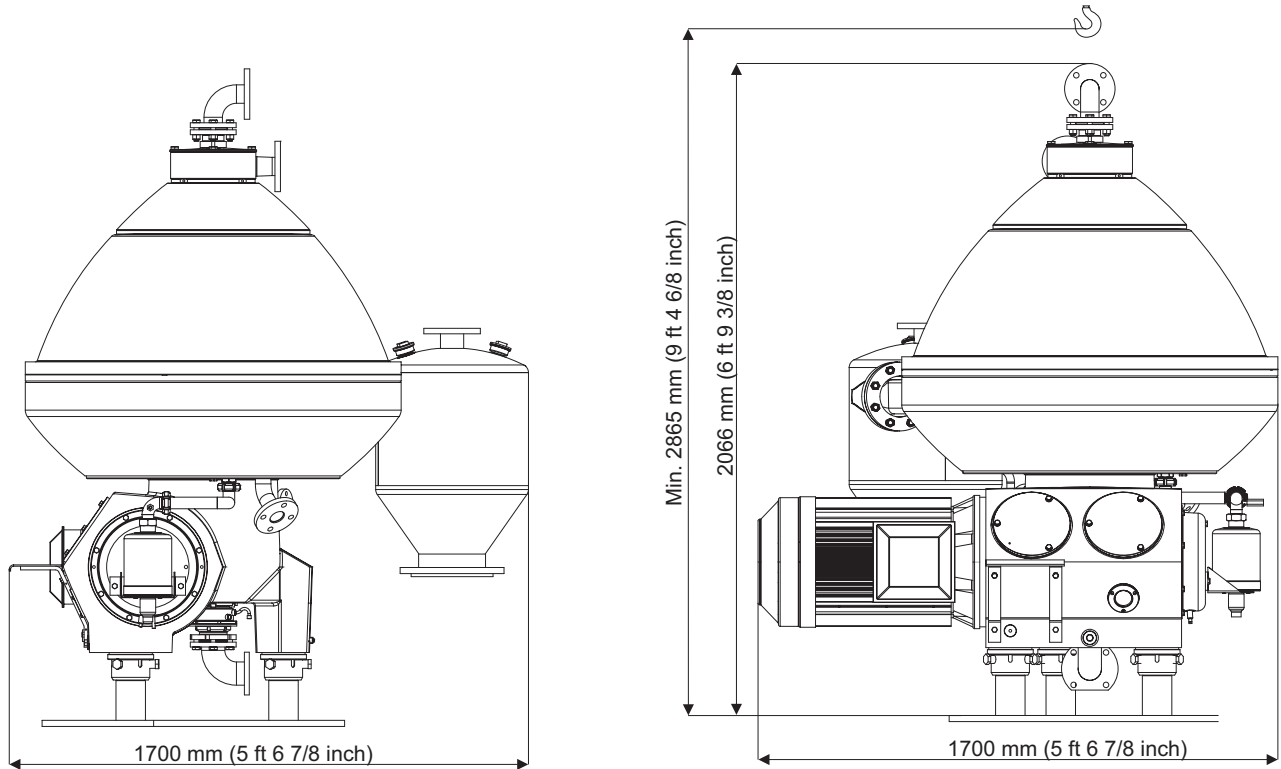

**How to contact Alfa Laval**

Up-to-date Alfa Laval contact details for all countries are always available on our website at [www.alfalaval.com](http://www.alfalaval.com).